

# **GRID INTERCONNECTION OF EMBEDDED GENERATION**

## **Part 2: Small-scale embedded generation**

### **Section 3: Simplified utility connection criteria for low-voltage connected generators**

This document does not have the status of a South African National Standard.



This specification is issued by  
the Standardization Section, Eskom  
on behalf of the  
User Group given in the foreword.

**Table of changes**

<b>Change No.</b>	<b>Date</b>	<b>Text affected</b>

Correspondence to be directed to

The NRS Projects Manager  
Standardization Section  
The Industry Association Resource Centre  
Eskom  
Private Bag X13  
Halfway House 1685

Telephone: (011) 651 6830  
Fax: (011) 651 6827  
E-mail: [nrs@eskom.co.za](mailto:nrs@eskom.co.za)

Website : <http://www.nrs.eskom.co.za>

Printed copies obtainable from

SABS Standards Division  
Private Bag X191  
Pretoria 0001

Telephone: (012) 428-7911  
Fax: (012) 344-1568  
E-mail: [sales@sabs.co.za](mailto:sales@sabs.co.za)

Website: <http://www.sabs.co.za>

COPYRIGHT RESERVED

Printed in the Republic of South Africa  
by the SABS Standards Division  
1 Dr Lategan Road, Groenkloof, Pretoria

## Acknowledgement

This section of NRS 097-2 is based on the work of Dr C. Carter-Brown, who was instrumental in developing the content of this specification.

## Foreword

This section of NRS 097-2 was prepared on behalf of the Electricity Suppliers Liaison Committee (ESLC) and approved by it for use by supply authorities.

This section of NRS 097-2 was prepared by a working group which, at the time of publication, comprised the following members:

Dr C Carter-Brown (Chairperson)	Technology Division, Eskom
M Bello	Technology Division, Eskom
Dr G Botha	Sustainability Division, Eskom
L Drotsche	Distribution Division, Eskom
Dr H Geldenhuys	Technology Division, Eskom
H Groenewald	Technology Division, Eskom
V Nundlal	Technology Standardization, Eskom
S Sewchurran	eThekweni Electricity
R van der Riet	City of Cape Town
A Whittaker	City Power Johannesburg (SOC) Ltd

A Manufacturers' Interest Group (MIG) was consulted on the contents of this section of NRS 097-2 and its comments were incorporated where the working group was in agreement. The MIG comprised the following members:

B Becker	MLT Drives
M Malengret	MLT Drives
A Schutz	MLT Drives
F Spencer	Alt-e Technologies

NRS 097 consists of the following parts and sections, under the general title *Grid interconnection of embedded generation*:

*Part 1: Distribution standard for the interconnection of embedded generation.*

*The specification sets out the minimum technical and statutory requirements for the connection of embedded generators to medium-voltage and high-voltage utility distribution networks. The specification applies to embedded generators larger than 1 000 kVA. (In course of preparation.)*

*Part 2: Small-scale embedded generation.*

*The specification sets out the technical requirements for the utility interface, the embedded generator and the utility distribution network with respect to embedded generation. The specification applies to embedded generators smaller than 1 000 kVA connected to **low-voltage** networks.*

*Section 1: Utility interface.*

*Section 2: Embedded generator requirements. (To be developed in the future.)*

*Section 3: Simplified utility connection criteria for low-voltage connected generators.*

*Section 4: Procedures for implementation and application. (To be developed in the future.)*

## **NRS 097-2-3:2014**

### **Foreword** *(concluded)*

In the definition of “utility”, reference is made to the “electricity distribution supply authority”. In South Africa this may be Eskom, or the municipal electricity service provider.

Annex A is for information only.

### **Introduction**

This section of NRS 097 is intended to guide South African distributors in terms of simple rules to be applied when applications for LV connected embedded generators are being assessed. The proposed criteria indicate the conditions under which LV connected generators can be connected to the utility grid without having to perform detailed network studies. Applications that do not meet these criteria will need to follow an alternative process, which might require detailed network studies.

### **Keywords**

generator, utility, shared, dedicated

## Contents

	Page
Acknowledgement	
Foreword	
Introduction	
<b>1</b> Scope .....	<b>3</b>
<b>2</b> Normative references .....	<b>3</b>
<b>3</b> Terms, definitions and abbreviations .....	<b>3</b>
<b>3.1</b> Terms and definitions .....	<b>3</b>
<b>3.2</b> Abbreviations .....	<b>4</b>
<b>4</b> Requirements.....	<b>4</b>
<b>4.1</b> General .....	<b>4</b>
<b>4.2</b> Shared LV feeders.....	<b>5</b>
<b>4.3</b> Dedicated LV feeders .....	<b>7</b>
<b>4.4</b> Additional requirements.....	<b>10</b>
<b>4.5</b> Simplified connection criteria.....	<b>11</b>
<b>4.6</b> Basis for the calculations.....	<b>13</b>
<b>5</b> Tests.....	<b>16</b>
<b>6</b> Markings.....	<b>17</b>
<b>7</b> Documentation.....	<b>17</b>
<b>Annex A</b> (informative) Notes on more detailed studies.....	<b>18</b>
<b>Bibliography</b> .....	<b>21</b>

This page intentionally left blank

## **GRID INTERCONNECTION OF EMBEDDED GENERATION**

### **Part 2: Small-scale embedded generation**

#### **Section 3: Simplified utility connection criteria for low-voltage connected generators**

##### **1 Scope**

This section of NRS 097-2 covers the requirements for simplified utility connection criteria for low-voltage connected generators. The requirements differentiate between customers supplied by shared and dedicated LV networks, but explicitly exclude lower income domestic electrification networks i.e. shared LV networks supplying customers with a Living Standard Measure of less than seven.

##### **2 Normative references**

The following documents contain provisions which, through reference in this text, constitute provisions of this section of NRS 097-2. All documents are subject to revision and, since any reference to a document is deemed to be a reference to the latest edition of that document, parties to agreements based on this specification are encouraged to take steps to ensure the use of the most recent editions of the documents listed below. Information on currently valid national and international standards can be obtained from the SABS Standards Division.

NRS 048-2, *Electricity supply – Quality of supply – Part 2: Voltage characteristics, compatibility levels, limits and assessment methods.*

NRS 048-4, *Electricity supply – Quality of supply – Part 4: Application practices for licencees.*

NRS 097-2-1, *Grid interconnection of embedded generation – Part 2: Small-scale embedded generation – Section 1: Utility interface.*

Grid Connection Code for Renewable Power Plants (RPPs) connected to the electricity Transmission System (TS) or the Distribution System (DS) in South Africa, Version 2.6, November 2012

##### **3 Terms, definitions and abbreviations**

For the purposes of this document, following terms, definitions and abbreviations apply.

### 3.1 Terms and definitions

**dedicated network**

section of the utility network that exclusively supplies a single customer/generator

NOTE A dedicated network can be a dedicated LV feeder, or a dedicated MV/LV transformer.

**generator size**

maximum change in active power flow at the point of utility connection for a generator trip (or rapid reduction in output) when generating at full active power output

NOTE Some or all of the power generated may be consumed by the customers' local loads. Where there is no local storage the generator size is the active power rating of the installed generation. In cases with local storage, the storage can be used to reduce the effective size of the generator by compensating for variations in generation output, hence the definition used above.

**shared network**

section of the utility network that supplies more than one customer/generator

**utility**

electricity distribution supply authority (see foreword) responsible for the low-voltage electricity network infrastructure in the area of the installation

### 3.2 Abbreviations

**ADMD:** after diversity maximum demand

**EG:** embedded generator

**LV:** low voltage

**MV:** medium voltage

**NMD:** notified maximum demand

**OLTC:** on-load tap changing

**RVC:** rapid voltage change

**SSEG:** small-scale embedded generator

## 4 Requirements

### 4.1 General

NOTE 1 The NRS 097-2 series of specifications specify the minimum technical requirements for LV generators connected to the South African grid, as aligned to the requirements of the grid connection code for renewable power plants connected to the electricity transmission system or the distribution system in South Africa.

NOTE 2 Requirements given in this section of NRS 097-2 should be used to evaluate LV generator grid interconnection applications. LV (230 V/400 V) connected generators that fall within these criteria are proposed to follow a simplified connection process that will not require detailed network studies.

NOTE 3 Simplified criteria rules are subject to the following:

- a) An individual limit of 25 % of NMD will typically support a penetration level (percentage of customers that install a generator) of 30 % to 50 %, which is considered a reasonable and acceptable compromise between restricting individual generator sizes versus restricting penetration levels.



- b) The network feeder design After Diversity Maximum Demand (ADMD) is unknown.
- c) The size of plant, type of generation, location of plant and date of installation of ALL generating plants should be captured and documented by the utility CONTINUALLY.

**4.1.1** All LV grid connected generator interconnection equipment should be type-test certified complying with the minimum technical requirements of NRS 097-2-1.

**4.1.2** Simplified connection of generator sizes should be limited to 350 kVA.

**4.1.3** The maximum permissible generation size of an individual LV customer is dependent on:

- a) the type of LV network. This depends on whether the LV network that supplies the customer is shared (supplies other customers) or dedicated (only supplies the customer in question), and
- b) the customer's notified maximum demand (NMD). The NMD in many cases is determined by the LV service connection circuit-breaker rating.

**4.1.4** Additional requirements linked to the size of the MV/LV transformer and maximum loading of the associated MV feeder are discussed this section of NRS 097-2.

**4.1.5** The LV fault level at the customer point of supply should be greater than 210 A.

NOTE Details of the selection of the 210 A fault level is discussed in annex C of NRS 097-2-1:2010.

**4.1.6** If the criteria in this standard are not met it does not imply that the proposed generator cannot be connected. Rather, more detailed studies are required to assess if the generator can be connected i.e. a simplified connection process cannot be followed (see annex A).

**4.1.7** Utilities may modify the criteria, or add additional criteria, to meet their specific requirements considering their network characteristics.

## **4.2 Shared LV feeders**

**4.2.1** The maximum individual generation limit in a shared LV feeder (see figure 1) is approximately 25 % of the customer's NMD, up to a maximum of 20 kVA (generators greater than 20 kVA should be connected through a dedicated LV feeder).

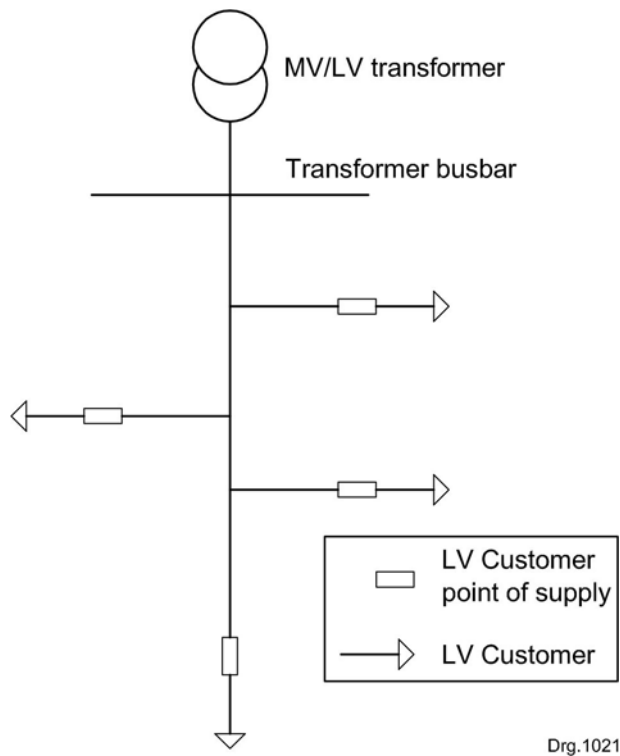

**Figure 1 — Shared LV feeder**

**4.2.2** The resulting maximum generator sizes for common domestic supply sizes are summarized in table 1.

NOTE The values have been adjusted to align with VDE-AR-N 4105 and hence vary slightly from 25 % of the NMD. For circuit-breaker sizes not included in table 1, the maximum individual generation limit is 25 % of the customer notified maximum demand, i.e. 25 % of the circuit-breaker size. The individual limit is only dependent on the service circuit-breaker rating, and not on the feeder After Diversity Maximum Demand (ADMD). Future refinements of these criteria will assess the incorporation of ADMD into the decision framework.

**Table 1 — Maximum individual generation limit in a shared LV (400 V/230 V) feeder**

1	2	3	4
Number of phases	Service circuit-breaker size	NMD kVA	Maximum individual generation limit kVA
1	20 A	4,6	1,2
1	60 A	13,8	3,68
1	80 A	18,4	4,6
3	60 A and 80 A	41,4	13,8 (4,6 per phase)

**4.2.3** In shared LV feeders, any generator greater than 4,6 kVA should be balanced across phases.

**4.2.4** In the case of LV customers with supplies greater than those given in table 1, the maximum individual generation limit in a shared LV feeder is 25 % of the customer’s NMD. For example, a LV customer with a 100 kVA NMD supplied through a shared LV feeder could connect up to  $100 \times 25 \% = 25$  kVA of generation. Since 25 kVA is greater than the 20 kVA limit for a shared

feeder, the maximum size is 20 kVA and as 20 kVA is greater than the 4,6 kVA single-phase limit, it shall be three-phase connected.

**4.2.5** If the maximum individual generation limit is exceeded, the customer could potentially be connected through a dedicated LV feeder, such that the generator is supplied through a dedicated LV feeder (and the dedicated LV feeder limits apply). Alternatively the customer can apply for an increased NMD e.g. if a customer with a single-phase 60 A supply wants to install a generator greater than 3,68 kVA, then the customer could apply for an upgraded supply to three-phase 60 A whereby the maximum generator limit increases to 13,8 kVA.

**4.2.6** In addition, the total generation supplied by shared LV feeders should be limited to 25 % of the MV/LV transformer rating. For example, a 200 kVA MV/LV transformer can supply up to 50 kVA of generation supplied through shared LV feeders connected to that transformer.

### 4.3 Dedicated LV feeders

**4.3.1** In dedicated LV feeders (see figure 2), the maximum individual generation limit is a function of:

- a) The notified maximum demand. The maximum generator size is limited to 75 % of the NMD. Generators greater than 4,6 kVA should be balanced across the available phases. Customers with dedicated single-phase supplies supplied by a dedicated MV/LV transformer (e.g. 16 kVA MV/LV dedicated supplies in rural areas) should be allowed to connect up to 13,8 kVA on that single-phase but should not exceed 75 % of their NMD.
- b) The dedicated feeder cable size is limited such that the voltage rise between the point of supply and transformer busbar is limited to 1 %. Figures 3 and 4 illustrate the maximum generator size as a function of the dedicated LV feeder cable size and length.

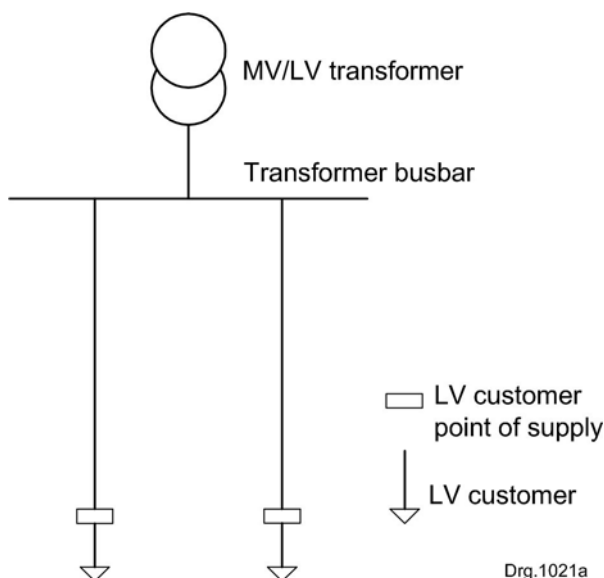

**Figure 2 — Dedicated LV feeder**

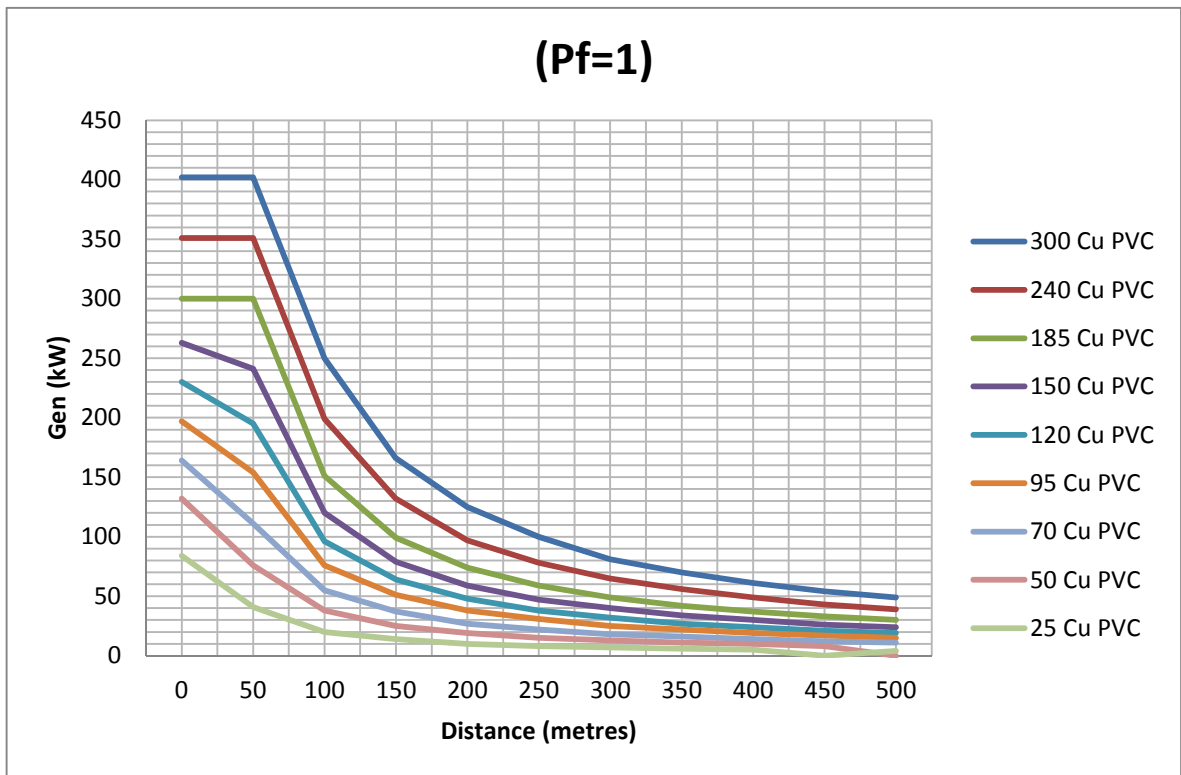

**Figure 3 — Dedicated LV feeder maximum generator sizes as a function of PVC copper cable size and distance**

NOTE The cable parameters in figure 3 were extracted from the, Aberdare Cables brochure, *Low Voltage Cable Range*.

c) The look-up table for figure 3 is shown in table 2.

**Table 2 — Look-up values for a dedicated LV feeder maximum generator sizes (kVA) as a function of PVC copper cable size and distance**

1	2	3	4	5	Size mm <sup>2</sup>					10
					300 Cu PVC	240 Cu PVC	185 Cu PVC	150 Cu PVC	120 Cu PVC	
Distance m	Generator sizes kVA									
	0	402	351	300	263	230	197	164	132	84
50	402	351	300	241	195	154	111	76	41	
100	250	199	151	120	96	76	55	38	20	
150	166	132	99	79	64	51	37	25	14	
200	125	97	74	59	48	38	27	19	10	
250	100	78	59	47	38	31	22	15	8	
300	81	65	49	40	32	25	18	13	7	
350	70	56	42	34	27	22	16	11	6	
400	61	49	37	30	24	19	14	10	5	
450	54	43	33	26	21	17	12	8	4,5	
500	49	39	30	24	19	15	11	7,5	4	

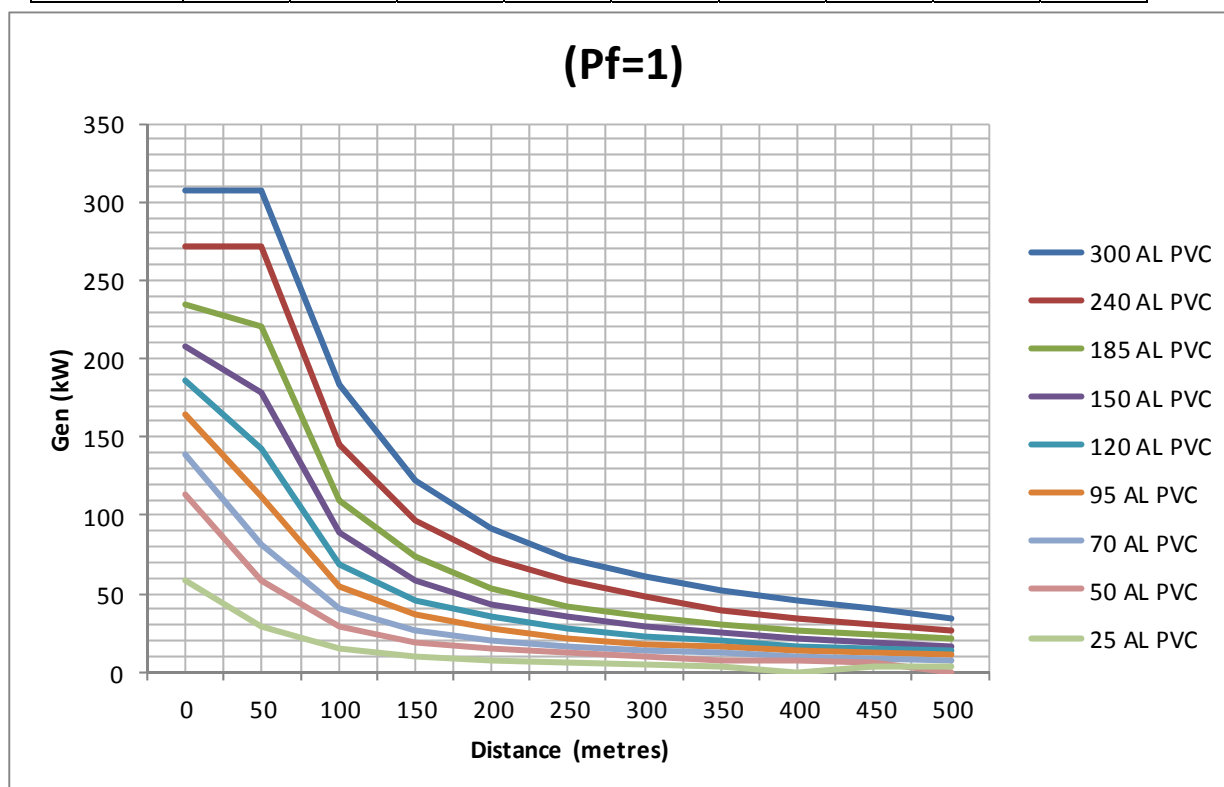

**Figure 4 — Dedicated LV feeder maximum generator sizes as a function of aluminium PVC cable size and distance**

NOTE The cable parameters in figure 4 were extracted from the Aberdare Cables brochure, *Low Voltage Cable Range*.

d) The look up table for figure 4 is shown in table 3.

**Table 3 — Look-up values for a dedicated LV feeder maximum generator sizes (kVA) as a function of aluminium (AL) PVC cable size and distance**

1	2	3	4	5	6	7	8	9	10
	<b>Sizes mm<sup>2</sup></b>								
	300 AL	240 AL	185 AL	150 AL	120 AL	95 AL	70 AL	50 AL	25 AL
<b>Distance m</b>	<b>Generator sizes kVA</b>								
0	307	271	234	208	186	164	139	113	59
50	307	271	221	179	143	112	81	58	29
100	184	145	110	89	69	55	41	29	15
150	122	97	74	58	46	37	27	19	10
200	92	73	53	43	35	28	20	15	7
250	73	58	42	35	28	22	16	12	6
300	61	48	35	29	23	18	14	10	5
350	52	39	30	25	20	16	12	8	4
400	46	34	26	22	17	14	10	7	3,5
450	41	30	24	19	15	12	9	6	3
500	34	27	21	17	14	11	8	5,5	3

**4.3.2** If the dedicated LV feeder cable size is the constraint, it could be upgraded.

**4.3.3** Connections that only supply generators will be made through a dedicated LV feeder i.e. if the customer does not have load and only injects power into the network, then the connection should be made through a dedicated feeder with a minimum size in accordance with figures 3 and 4. As the customer is not a conventional load and does not have an NMD, the maximum generator size will be limited by the dedicated LV feeder size (figures 3 and 4) and the maximum MV/LV transformer limit (see additional requirements in 4.4).

#### 4.4 Additional requirements

**4.4.1** The following requirements apply in addition to the requirements for shared and dedicated LV feeder connected generators:

- a) the total generation (i.e. shared LV generation and dedicated LV generation) supplied by a MV/LV transformer should be less than 75 % of the MV/LV transformer rating, and
- b) the total generation supplied by a MV feeder should be less than 15 % of the MV feeder peak load.

**4.4.2** In the case of non-compliance with the criteria in 4.4.1(a) and 4.4.1(b), additional generation does not meet the simplified connection criteria. Therefore, it cannot be connected to the network without further detailed studies.

**4.4.3** This edition of NRS 097-2-3 does not explicitly provide guidance on utility protection and fault level implications, which will be included in a future revision. Fault level related issues are not anticipated for inverter based generators as the fault current contribution is typically limited to the converter current rating. Equipment fault current ratings should be checked for synchronous or asynchronous generators greater than 13,8 kVA.

#### 4.5 Simplified connection criteria

A summary of the connection criteria is shown in figure 5, and a flow chart that illustrates the simplified connection technical evaluation criteria is given in figure 6.

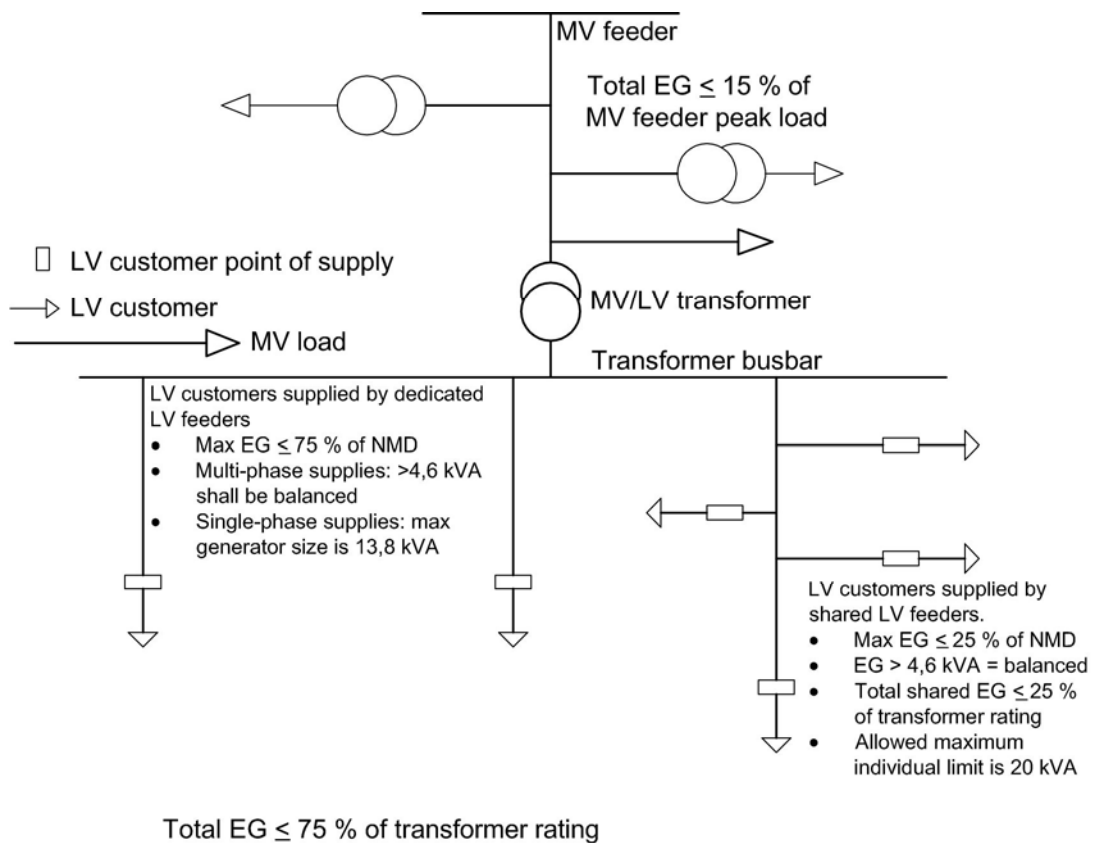

Drg.1021b

**Figure 5 — Summary of simplified connection criteria**

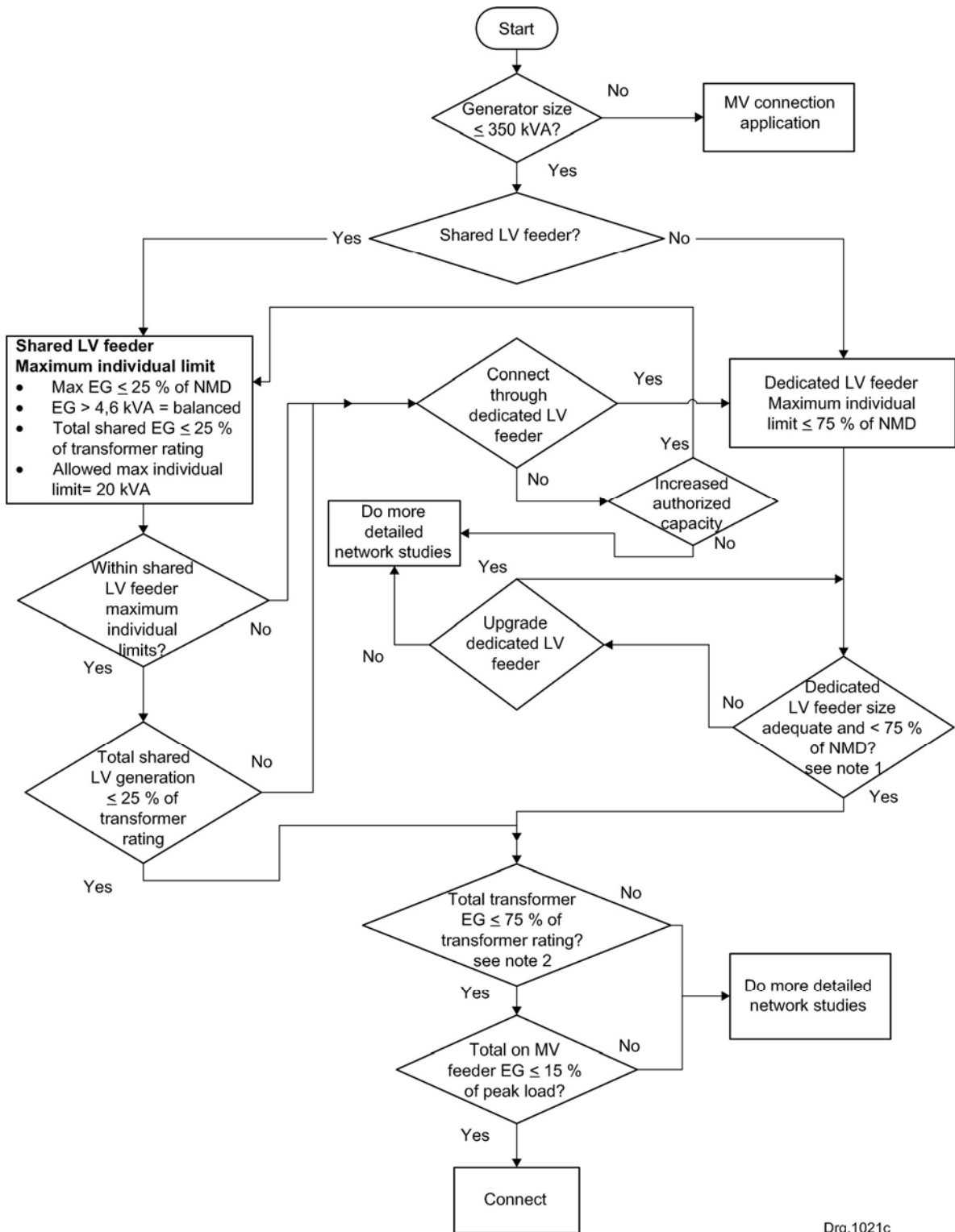

Drg.1021c

NOTE 1 See cable size plots in figures 3 and 4.

NOTE 2 Total of generation supplied by shared LV feeders and dedicated LV feeders for the MV/LV transformer concerned.

Figure 6 — Flow chart of simplified connection technical evaluation criteria



## 4.6 Basis for the calculations

### 4.6.1 General

NOTE 1 The proposed criteria in this section of NRS 097-2 have been guided by

- a) the approaches used in other countries and utilities, as informed by work within Cigre, and specifically Cigre working group C6.24. The intention is to adopt best practice as already applied in other utilities that have considerable experience with LV connected generators; and
- b) the application of specific technical criteria on models that represent typical South African LV networks.

NOTE 2 It is intended that the criteria will be enhanced and revised as more detailed studies are performed in the future and that the industry can learn from the application of these criteria.

### 4.6.2 The technical limits that constrain the amount of generation are as follows

- a) thermal ratings of equipment (lines, cables and transformers) may not be exceeded;
- b) LV voltage regulation should be within the limits specified in NRS 048-2 (LV voltages at the customer point of supply should be within  $\pm 10\%$ );
- c) the maximum change in LV voltage (due to voltage drop/rise in the MV/LV transformer and LV feeders) due to embedded generators is limited to 3%. This is a common international practice where the generation is variable. This will ensure that voltage changes due to short-term variations in generation output are within acceptable limits for example every time there is a cloud transient the LV voltages should not vary by more than 3% (as photo-voltaic output changes). It is important to note that the generation supplies loads that would otherwise be supplied by the utility network. From a voltage change perspective, it does not matter how much of the generation is consumed locally or fed back into the network. When the generation output changes, the loading in the utility network changes accordingly as the utility network supplies loads that would have been supplied by the embedded generator. Hence voltage change magnitudes (due to changes in generation output) are dependent on the generation size, and not on the net export magnitude into the utility network;
- d) islanding on the utility network is not allowed;
- e) the fault level at the customer point of supply should be greater than 210 A, or the minimum fault level at which the generator is rated.

### 4.6.3 The application of the limits given in 4.6.2 resulted in the following proposed criteria:

- a) Voltage rise on LV feeders should be limited to a maximum of 1%. This value is informed by the NRS 048 voltage limits, MV voltage control practices and the MV/LV transformer voltage ratio and tap settings (see table 4).
- b) Voltage rise across the MV/LV transformer should be limited such that the NRS 048-2 voltage limits are not exceeded (see table 5). The maximum generation connected to a MV/LV transformer is limited to 75% of the transformer rating understanding that this may result in overvoltage problems on LV feeders where there is further voltage rise. The 75% limit is hence high but in reality the net flow through the transformer into the MV network is expected to be significantly less due to the customer loads. A 75% limit will also ensure that the transformer will not be overloaded during periods of maximum generation and minimum loading.
- c) The individual customer limit of 75% of NMD on dedicated LV feeders is informed by the MV/LV transformer limit of 75%. This approach provides customers with equitable access to the available generation capacity as limited by the MV/LV transformer rating. It will also ensure

that service cables will not be overloaded under conditions of maximum generation and low loading.

- d) The dedicated LV feeder minimum size is based on a maximum voltage rise of 1 % (figure 3 and figure 4). The 1 % value is in accordance with table 4.
- e) The individual customer limit of 25 % of NMD on shared LV feeders is informed by an analysis of typical LV feeder designs whereby the individual generator size was scaled as a function of the design ADMD and the generation penetration level (percentage of customers that install a generator). The voltage rise and change in voltage were calculated assuming that the installed generation is reasonably balanced (connected to the same phases as the load). Setting the individual customer maximum generation limit requires that the penetration level value be established such that technical limits are complied with. An individual limit of 25 % of NMD will typically support a penetration level of 30 % to 50 %, which is considered a reasonable and acceptable compromise between restricting individual generator sizes versus restricting penetration levels. It shall be noted that a primary limitation is the maximum voltage change of 3 %.
- f) The total generation connected to a MV feeder is limited to 15 % of the MV feeder maximum loading. This value is informed by practices in the United States and Europe, and is based on the ratio of maximum to minimum feeder loading for typical consumer load profiles. A limit of 15 % will ensure a low probability of reverse power flow into the MV feeder source, thereby preventing voltage rise in the MV feeder and reducing the possibility of an island for operation of MV switches and protection.

Table 4 — Calculation of maximum LV voltage rise

1	2	3
Parameter	Value	Comment
Maximum MV voltage for normal operating condition	104 %	This is the typical maximum MV voltage based on normal MV OLTC settings.
Transformer nominal voltage in nominal tap	105,0 %	This is the built-in boost of the standard MV/LV transformer in nominal tap i.e. transformers with a nominal secondary voltage of 420 V are installed.
Minimum transformer loading pu no generation	30 %	This is the minimum transformer loading as a percentage of the transformer rating, and it is the load at the time of maximum MV voltage.
Maximum generation pu of transformer rating	25 %	This is the maximum generation to be connected, as expressed as a percentage of the transformer rated capacity, i.e. 25 % would mean that 25 kVA can be connected to a 100 kVA transformer.
Transformer Z	6 %	Rated impedance of transformer.
Transformer X/R	5	X/R ratio of transformer.
Maximum LV no load no generation for normal operating	109,2 %	This is the calculated maximum LV voltage at the transformer under maximum MV voltage, no load and no generation.
Net transformer loading, minimum load, maximum generation	5 %	This is the calculated difference between the minimum load and maximum generation. It assumes that both are at unity power factor. A negative value means that power is flowing back into the MV network.
Transformer R	1,2 %	This is the transformer resistance as calculated from the rated impedance and X/R ratio.
Transformer V drop	0,1 %	This is the calculated voltage drop over the transformer. Negative value is a voltage rise.
Transformer LV voltage at minimum load, maximum generation	109,1 %	This is the calculated maximum LV voltage at the LV terminals of the transformer under the condition of maximum MV, minimum LV load and maximum generation. It should be restricted to 110 %.
Maximum LV voltage allowed	110 %	In accordance with NRS 048-2.
Maximum LV voltage rise	0,9 %	Difference between maximum LV voltage at transformer and maximum limit allowed.

**4.6.4** The calculated result is 0,9 %, but given the uncertainty in the input parameters, a value of 1 % is proposed. In accordance with table 5, the application of the 1 % voltage rise and maximum generation limit of 75 % of the MV/LV transformer size may result in cases of voltage levels in excess of NRS 048-2 limits.

**Table 5 — Calculation of maximum generation connected to a MV/LV transformer**

1	2	3
Parameter	Value	Comment
Maximum MV voltage for normal operating condition	104 %	This is the typical maximum MV voltage based on normal MV OLTC settings.
Transformer nominal voltage in nominal tap	105,0 %	This is the built-in boost of the standard MV/LV transformer in nominal tap, i.e. transformers with a nominal secondary voltage of 420 V are installed.
Minimum transformer loading pu no generation	0 %	This is the minimum transformer loading as a percentage of the transformer rating, and it is the load at the time of maximum MV voltage.
Maximum generation pu of transformer rating	75 %	This is the maximum generation to be connected, as expressed as a percentage of the transformer rated capacity, i.e. 50 % would mean that 50 kVA can be connected to a 100 kVA transformer.
Transformer Z	6 %	Rated impedance of transformer
Transformer X/R	5	X/R ratio of transformer
Maximum LV no load no generation for normal operating	109,2 %	This is the calculated maximum LV voltage at the transformer under maximum MV voltage, no load and no generation.
Net transformer loading, minimum load, maximum generation	- 75 %	This is the calculated difference between the minimum load and maximum generation. It assumes that both are at unity power factor. A negative value means that power is flowing back into the MV network.
Transformer R	1,2 %	This is the transformer resistance as calculated from the rated impedance and X/R ratio.
Transformer V drop	- 0,9 %	This is the calculated voltage drop over the transformer. Negative value is a voltage rise.
Transformer LV voltage at minimum load, maximum generation	110,1 %	This is the calculated maximum LV voltage at the LV terminals of the transformer under the condition of maximum MV, minimum LV load and maximum generation. It should be restricted to 110 %.
LV voltage rise in LV feeder	1 %	Maximum allowed LV feeder voltage rise (see table 4)
Maximum LV voltage	111,1 %	Maximum LV voltage due to voltage rise in MV/LV transformer and LV feeder

**4.6.5** At a generation level of 75 % of the MV/LV transformer rating, the maximum LV voltage at the MV/LV transformer LV terminals rises to 110,1 % which is at the upper limit of 110 %. If the LV voltage is allowed to rise by a further 1 % in the LV feeders then the maximum LV voltage is 111,1 % which is above the NRS 048-2 limit. However in reality there will be load that will reduce the effect of the voltage rise. As such, a generation limit of 75 % is proposed, noting that in some situations the voltage limit will be exceeded and remedial action will be necessary.

## 5 Tests

Not applicable.

**6 Markings**

Not applicable.

**7 Documentation**

Not applicable.

## **Annex A**

(informative)

### **Notes on more detailed studies**

NOTE 1 This annex gives guidelines on additional studies that may be required when customers are connected in situations where criteria other than the simplified connection criteria apply. These guidelines are not intended to be exhaustive, but only to guide planners on additional criteria.

NOTE 2 It may be beneficial to evaluate the quality of supply on the network for a period (a minimum of seven days) before concluding on the suitability of the connection point.

#### **A.1 Fault level at customer point**

Determine the short-circuit level (fault level) at the customer point to the desired accuracy. The fault level determines the potential impact that the generator will have on the network.

#### **A.2 Fault level at SSEG connection point**

Compare the fault level at the SSEG connection point to the test fault level of the SSEG (as given in the test certificate). A basic rule of thumb is that the impact of the connected device would vary inversely proportional to the ratio of the fault level. This will be regarded as an equivalent expected impact on the network.

#### **A.3 Voltage rise**

**A.3.1** Calculate the expected voltage rise due to the connection of the SSEG at full capacity and the normal operating power factor. Confirm that the voltage rise due to the SSEG is acceptable.

**A.3.2** According to VDE-AR-N 4105, the maximum voltage rise due to all generators connected to an LV network should not exceed 3 %.

**A.3.3** The acceptable voltage rise due to any single generator should be designed in line with the specific network.

**A.3.4** Care should be taken on typical residential feeders that any single-phase generator is connected to a phase that is loaded heavier during expected generation periods.

#### **A.4 Unbalance**

**A.4.1** Generators should generally improve any unbalance experienced on a network. The potential contribution should be confirmed.

**A.4.2** The equivalent expected contribution to voltage unbalance should be less than that specified by NRS 048-4 ( See annex D, Generic emission limits evaluated under stage 1).

**A.4.3** Care should be taken on typical residential feeders that any single-phase generator is connected to a phase that is loaded heavier during expected generation periods.

**A.4.4** Larger units may have to be apportioned under stage 2 in accordance with NRS 048-4.

## **Annex A**

*(continued)*

### **A.5 Flicker**

**A.5.1** Although flicker is becoming less of a problem, flicker still needs to be managed;

**A.5.2** Any start-up voltage change should be limited to 5 % (RVC limit on MV networks for up to four events per day);

**A.5.3** The equivalent expected contribution to voltage flicker should be less than that specified by NRS 048-4 ( See annex D, Generic emission limits evaluated under stage 1).

**A.5.4** Larger units may have to be compared against apportioned under stage 2 in accordance with NRS 048-4.

### **A.6 Harmonics**

**A.6.1** Contribution to harmonic distortion is a major concern for any inverter-based generator, including units with power electronic devices connected for control or other operational reasons.

**A.6.2** The equivalent expected contribution to voltage harmonics should be less than that specified by NRS 048-4 (see annex D, Generic emission limits evaluated under stage 1).

**A.6.3** The recommended current harmonic emission limits can be calculated according to the apportioning stage 2 procedure in NRS 048-4, or can be compared to A.1 (see VDE-AR-N 4105).

### **A.7 Protection equipment**

**A.7.1** Confirm that the fault level contribution of the SSEG will not exceed the ratings of circuit-breakers installed in the system(i.e. the customer that connects the SSEG, neighbouring customers and upstream circuit-breakers). The fault level contribution can be obtained from the SSEG test certificate.

**A.7.2** If the fault level contribution from the SSEG is unavailable, the following should be assumed:

- a) in the case of synchronous generators: eight times the rated current;
- b) in the case of asynchronous generators: six times the rated current;
- c) in the case of inverter based generators: one time the rated current.

**A.7.3** Further protection checks may be necessary, for example recloser settings, protection coordination.

## Annex A

(concluded)

**Table A.1 — Maximum harmonic current emissions**

(Source: VDE-AR-N 4105)

1	2	3	4	5	6
Harmonic number h (odd)	Permissible maximum current Ampere per MVA of fault level	Harmonic number h (even)	Permissible maximum current Ampere per MVA of fault level	Inter-harmonic number h (all)	Permissible maximum current Ampere per MVA of fault level
3	3	2-40	1,5/h	2-41	1,5/h
5	1,5				
7	1				
9	0,7				
11	0,5				
13	0,4				
15	0,25 <sup>a</sup>				
17	0,3				
19	0,25				
21	0,18 <sup>a</sup>				
23	0,2				
25-41	0,15 × 25/h				
42-178	4,5/h				
NOTE Group all components above 40 <sup>th</sup> in bands of 200 Hz as in SANS 61000-4-7, where “h” indicates the mid-band (harmonic or inter-harmonic component).					
<sup>a</sup> Not defined in VDE-AR-N 4105.					



## Bibliography

Aberdare Cables Brochure. *Low Voltage Cable Range*. Edition 4

SANS 9001/ISO 9001, *Quality management systems – Requirements*.

SANS 61000-4-7/IEC 61000-4-7, *Electromagnetic compatibility (EMC) – Part 4-7: Testing and measurement techniques – General guide on harmonics and interharmonics measurements and instrumentation, for power supply systems and equipment connected thereto*.

VDE-AR-N 4105, *Generators connected to the low-voltage distribution network – Technical requirements for the connection to and parallel operation with low-voltage distribution networks*.

---



This page has been left blank intentionally

---

## **SABS – Standards Division**

The objective of the SABS Standards Division is to develop, promote and maintain South African National Standards. This objective is incorporated in the Standards Act, 2008 (Act No. 8 of 2008).

### **Amendments and Revisions**

South African National Standards are updated by amendment or revision. Users of South African National Standards should ensure that they possess the latest amendments or editions.

The SABS continuously strives to improve the quality of its products and services and would therefore be grateful if anyone finding an inaccuracy or ambiguity while using this standard would inform the secretary of the technical committee responsible, the identity of which can be found in the foreword.

The SABS offers an individual notification service, which ensures that subscribers automatically receive notification regarding amendments and revisions to South African National Standards.

Tel: +27 (0) 12 428 6883 Fax: +27 (0) 12 428 6928 E-mail: [sales@sabs.co.za](mailto:sales@sabs.co.za)

### **Buying Standards**

Contact the Sales Office for South African and international standards, which are available in both electronic and hard copy format.

Tel: +27 (0) 12 428 6883 Fax: +27 (0) 12 428 6928 E-mail: [sales@sabs.co.za](mailto:sales@sabs.co.za)

South African National Standards are also available online from the SABS website <http://www.sabs.co.za>

### **Information on Standards**

The Standards Information Centre provides a wide range of standards-related information on both national and international standards. The Centre also offers an individual updating service called INFOPLUS, which ensures that subscribers automatically receive notification regarding amendments to, and revisions of, international standards.

Tel: +27 (0) 12 428 7911 / 0861 27 7227 Fax: +27 (0) 12 428 6928 E-mail: [info@sabs.co.za](mailto:info@sabs.co.za)

### **Copyright**

The copyright in a South African National Standard or any other publication published by the SABS Standards Division vests in the SABS or, in the case of a South African National Standard based on an international standard, in the organization from which the SABS adopted the standard under licence or membership agreement. In the latter case, the SABS has the obligation to protect such copyright. Unless exemption has been granted, no extract may be reproduced, stored in a retrieval system or transmitted in any form or by any means without prior written permission from the SABS Standards Division. This does not preclude the free use, in the course of implementing the standard, of necessary details such as symbols, and size, type or grade designations. If these details are to be used for any purpose other than implementation, prior written permission must be obtained.

Details and advice can be obtained from the Manager – Standards Sales and Information Services.

Tel: +27 (0) 12 428 6883 Fax: +27 (0) 12 428 6928 E-mail: [sales@sabs.co.za](mailto:sales@sabs.co.za)